

Table No.1 Bushings Specifications and Dimensions(inches)

Bushing No.	A	B	D Bolt Circle	Capscrews		Stock Bore Range			Wrench Torque in.lbs.	Torque Cap.Lb. In.	Wt. lbs
				Dia.	length	min	Max				
							Std Kw.	Shallow Kw.			
1008	1 25/64	7/8	1 21/64	1/4	1/2	1/2	7/8	1	55	1,200	.27
1108	1.511	7/8	1 29/64	1/4	1/2	1/2	1	1 1/8	55	1,300	.33
1210	1 7/8	1	1 3/4	3/8	5/8	1/2	1 1/4	1 1/4	175	3,600	.61
1215	1 7/8	1 1/2	1 3/4	3/8	5/8	1/2	1 1/4	1 1/4	175	3,550	.80
1610	2 1/4	1	2 1/8	3/8	5/8	1/2	1 1/2	1 5/8	175	4,300	.90
1615	2 1/4	1 1/2	2 1/8	3/8	5/8	1/2	1 1/2	1 5/8	175	4,300	1.2
2012	2 3/4	1 1/4	2 5/8	7/16	7/8	1/2	1 7/8	2	280	7,150	1.70
2517	3 3/8	1 3/4	3 1/4	1/2	1	1/2	2 1/4	2 1/2	430	11,600	3.5
2525	3 3/8	2 1/2	3 1/4	1/2	1	3/4	2 1/4	2 1/2	430	11,300	4.9
3020	4 1/4	2	4	5/8	1 1/4	15/16	2 3/4	3	800	24,000	6.5
3030	4 1/4	3	4	5/8	1 1/4	15/16	2 3/4	3	800	24,000	9.2

TAPER-LOCK BUSHINGS 1008-3030

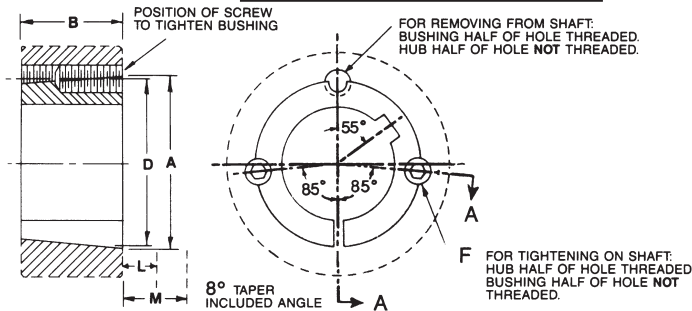

Table NO.2 Stock Bushing Bore

	1008	1108	1210	1215	1610	1615	2012	2517	2525	3020	3030
1/2	x	x	x	x	x	x	x	x	-	-	-
9/16	x	x	x	x	x	x	x	x	-	-	-
5/8	x	x	x	x	x	x	x	x	-	-	-
11/16	x	x	x	x	x	x	x	x	-	-	-
3/4	x	x	x	x	x	x	x	x	x	-	-
13/16	x	x	x	x	x	x	x	x	x	-	-
7/8	x	x	x	x	x	x	x	x	x	-	-
15/16	x	x	x	x	x	x	x	x	x	x	x
1	x	x	x	x	x	x	x	x	x	x	x
1 1/16	-	x	x	x	x	x	x	x	x	x	x
1 1/8	-	x	x	x	x	x	x	x	x	x	x
1 3/16	-	-	x	x	x	x	x	x	x	x	x
1 1/4	-	-	x	x	x	x	x	x	x	x	x
1 5/16	-	-	-	-	x	x	x	x	x	x	x
1 3/8	-	-	-	-	x	x	x	x	x	x	x
1 7/16	-	-	-	-	x	x	x	x	x	x	x
1 1/2	-	-	-	-	x	x	x	x	x	x	x
1 9/16	-	-	-	-	x	x	x	x	x	x	x
1 5/8	-	-	-	-	x	x	x	x	x	x	x
1 11/16	-	-	-	-	-	x	x	x	x	x	x
1 3/4	-	-	-	-	-	-	x	x	x	x	x
1 13/16	-	-	-	-	-	-	x	x	x	x	x
1 7/8	-	-	-	-	-	-	x	x	x	x	x
1 15/16	-	-	-	-	-	-	-	x	x	x	x
2	-	-	-	-	-	-	-	x	x	x	x
2 1/16	-	-	-	-	-	-	-	x	x	x	x
2 1/8	-	-	-	-	-	-	-	x	x	x	x
2 3/16	-	-	-	-	-	-	-	x	x	x	x
2 1/4	-	-	-	-	-	-	-	x	x	x	x
2 5/16	-	-	-	-	-	-	-	x	x	x	x
2 3/8	-	-	-	-	-	-	-	x	x	x	x
2 7/16	-	-	-	-	-	-	-	x	x	x	x
2 1/2	-	-	-	-	-	-	-	x	x	x	x
2 9/16	-	-	-	-	-	-	-	-	-	x	x
2 5/8	-	-	-	-	-	-	-	-	-	x	x

Table No.2 Stock Bores

	3020	3030
2 11/16	x	x
2 3/4	x	x
2 13/16	x	x
2 7/8	x	x
2 15/16	x	x
3	x	x

Table No.3 Standard Keyseats

Bore Range	Keyseat	Bore Range	Keyseat
1/2-9/16	1/8x1/16	2 5/16-2 3/4	5/8x5/16
5/8-7/8	3/16x3/32	2 13/16-3 1/4	3/4x3/8
15/16-1 1/4	1/4x1/8	3 3/8-3 3/4	7/8x7/16
1 5/16- 1 3/8	5/16x5/32	3 7/8-4 1/2	1x1/2
1 7/16-1 3/4	3/8x3/16	4 5/8-5	1 1/4x5/8
1 13/16-2 1/4	1/2x1/4		

NOTE: All the above items are made of STEEL; 1 3/8 Bore Bushings also available with 3/8x3/16 Kw.

Taper Bore Bushings (Steel)

3535 thru 5050

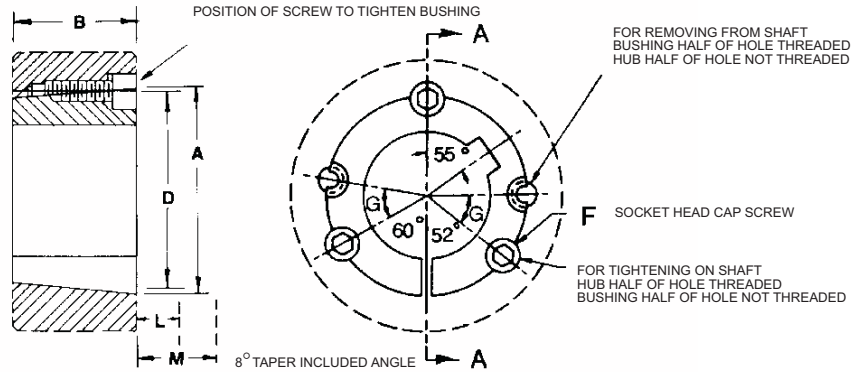

3535 thru 5050 Sizes

BUSH NO,	A	B	D	SET SCREWS	G
3535	5	3 1/2"	4.83	1/2x1 1/2	40°
4040	5 3/4	4"	5.54	5/8x1 3/4	40°
4545	6 3/8	4 1/2"	6.13	3/4x2	40°
5050	7	5"	6.72	7/8x2 1/4	37°

Stock Bushing Bore

Table NO. 3

Bore Range D[mm]	Width [mm]	Depth [mm]
10-12	4	1.8
13-17	5	2.3
18-22	6	2.8
23-30	8	3.3
31-38	10	3.3
39-44	12	3.3
45-50	14	3.8
51-58	16	4.3
59-65	18	4.4
66-75	20	4.9
76-85	22	5.4
86-95	25	5.4
96-110	28	6.4
111-130	32	7.4

Table NO.2

	3535	4040	4545	5050
1 3/16	x			
1 1/4	x			
1 5/16	x			
1 3/8	x			
1 7/16	x	x	-	-
1 1/2	x	x	-	-
1 9/16	x	-	-	-
1 5/8	x	x	-	-
1 11/16	x	x	-	-
1 3/4	x	x	-	-
1 13/16	-	x	-	-
1 7/8	x	x	-	-
1 15/16	x	x	x	-
2	x	x	x	x
2 1/16	-	-	-	-
2 1/8	x	x	-	-
2 3/16	x	x	x	-
2 1/4	x	x	-	-
2 5/16	x	x	-	-
2 3/8	x	x	x	-
2 7/16	x	x	x	x
2 1/2	x	x	-	x
2 9/16	-	x	-	-
2 5/8	x	x	x	-

Table No.2

	3535	4040	4545	5050
2 11/16	x	x	-	-
2 3/4	x	x	x	-
2 13/16	-	x	-	-
2 7/8	x	x	x	-
2 15/16	x	x	x	x
3	x	x	x	-
3 1/16	x	-	-	-
3 1/8	x	x	x	-
3 3/16	x	x	x	-
3 1/4	x	x	x	-
3 5/16	x	x	-	-
3 3/8	x	x	x	x
3 7/16	x	x	x	x
3 1/2	x	x	x	-
3 9/16	-	x	-	-
3 5/8	-	x	x	x
3 11/16	-	x	x	-
3 3/4	-	x	x	-
3 13/16	-	x	-	-
3 7/8	-	x	x	x
3 15/16	-	x	x	x
4	-	x	x	x
4 1/8	-	-	x	-
4 3/16	-	-	x	-
4 1/4	-	-	x	x
4 3/8	-	-	x	x
4 7/16	-	-	x	x
4 1/2	-	-	x	x
4 7/8	-	-	-	x
4 15/16	-	-	-	x
5	-	-	-	x

Table NO. 3

BUSH NO,	BORE mm
1008	10,11,12,14,15,16,18,19,20,22,24,25
1108	10,11,12,14,15,16,18,19,20,22,24,25,28
1210 1215	11,12,14,15,16,18,19,20,22,24,25,28,30,32
1310	14,15,16,18,19,20,22,24,25,28,30,32,35
1610 1615	14,15,16,18,19,20,22,24,25,28,30,32,35,38,40,42
2012	18,19,20,22,24,25,28,30,32,35,38,40,42,45,48,50,
2517 2525	20,22,24,25,28,30,32,35,38,40,42,45,48,50,55,60
3020 3030	25,28,30,32,35,38,40,42,45,48,50,55,60,65,70,75
3525 3535	35,38,40,42,45,48,50,55,60,65,70,75,80,85,90,
4030 4040	40,42,45,50,60,65,70,75,80,85,90,95,100
4535 4545	55,60,65,70,75,80,85,90,95,100,105,110,
5040 5050	60,65,70,75,80,85,90,95,100,105,110,115,120,125,

NOTE: All the above items are made of STEEL
1 3/8 Bore Bushings also available with 3/8x3/16 Kw.